

MASTER ABRASIVES

Special Purpose Grinding Machine

CASE STUDY

#1037

Workpiece:	Grinding of Eccentric Shaft (utilization of Manual Fixture)
Size Variation:	< 0.002mm
Taper on OD:	< 0.003mm
Eccentricity:	< ± 0.004mm
Surface Finish:	0.2 μ Ra
Uniqueness of Solution:	<ul style="list-style-type: none">• Economic• Easy and quick set-up change• Less part; easy to maintain

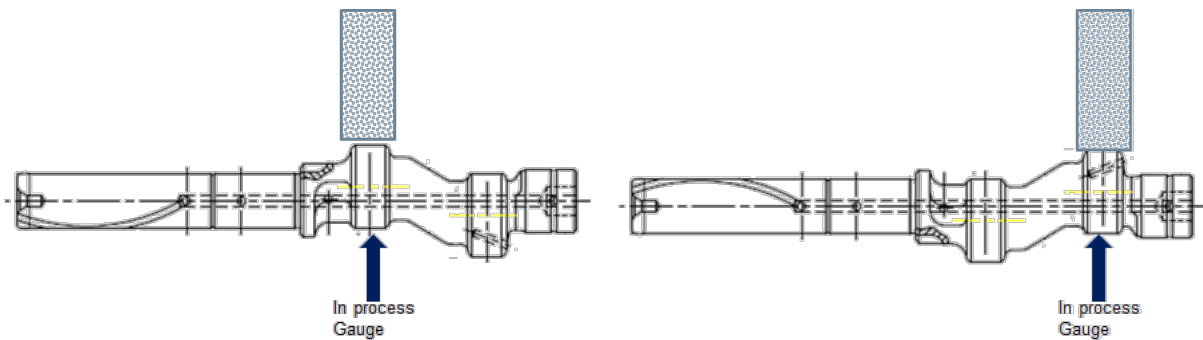

Copyright © 2020 Master Abrasives Ltd

CONTACT US FOR MORE INFORMATION

**MASTER
ABRASIVES**

T:01327-703813

sales@master-abrasives.co.uk

www.master-abrasives.co.uk